

# MSD IGNITION™ INSTALLATION INSTRUCTIONS

## MSD MC-3 MOTORCYCLE IGNITION PN 4223

The MSD MC-3 Ignition can be used on 1, 2 or 4-cylinder engines using one or two coils. The MC-3 will operate with conventional points or from the amplifier of an electronic breakerless system. Capacitive discharge (CDI) units cannot trigger the MSD.

**WARNING:** During installation, always disconnect the battery cables. When disconnecting the battery, always remove the Negative cable first and install it last.

**Note:** The MSD MC-3 will not work with capacitive discharge (CDI) motorcycles.

### Parts Included

1 - MSD MC-3 Ignition Control Unit                      6 - RPM Modules (5,000, 7,000, 9,000, 10,000, 11,000, 12,000 rpm)  
1 - Motorcycle Cable Assembly                              1 - Parts Bag

**Note:** It is recommended that you have the Service Manual for your motorcycle for the installation.

## TECH TIPS

The following are technical tips that will help you get the most out of your MSD MC-3 Ignition.

**Battery:** The battery is a very important component of your ignition system. The battery should be rated at no less than 10 amp/hours whether you have a charging system or not. If you do not have a charging system, allow at least 10 amp/hours per each half hour of use. Never start or run the engine while a battery charger is connected. Some chargers can produce voltage spikes that may damage the ignition components.

**Coils:** The MSD MC-3 will work with factory and most aftermarket coils. Better spark energy is received at the plug if lower resistance coils are used (1.5 ohm). However for maximum ignition output, an MSD Motorcycle Coil, PN 8204 is recommended. The MSD coil is designed specifically for use with the MC-3 Ignition. It has less resistance and a high turns ratio to match the full capability of the MC-3.

**WARNING:** Do not touch or connect any test equipment, accessories, etc. to the coil terminals.

**Spark Plugs:** The increased spark energy of the MC-3 allows you to run a wider spark plug gap (.045"-.060"). The result is more predictable ignition and improved performance.

**Spark Plug Wires:** Only magnetic suppression wires should be used with the MC-3 Ignition. Magnetic suppression wires, such as the MSD Heli-Core or Super Conductor wires, suppress electro magnetic interference (EMI) that is emitted. If not suppressed, this EMI noise may interfere with any electronic components on the motorcycle. **DO NOT use Solid Core wires.**

## CYLINDER SELECT

The MC-3 is programmed at the factory for 4-cylinder, four stroke or 2-cylinder, and one 1-cylinder two stroke engines. To program the unit for different applications, see the chart in Figure 1.

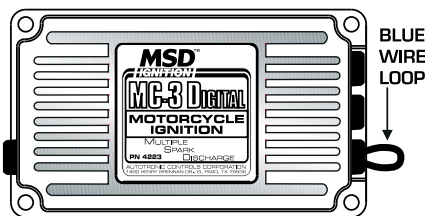

CYLINDER	FOUR STROKE	TWO STROKE
1	CUT LOOP	NO MODIFICATIONS
2	CUT LOOP	NO MODIFICATIONS
4	NO MODIFICATIONS	-----

**Figure 1 Cylinder Select Wire Loop.**

## MOUNTING

The MC-3 Ignition Unit may be mounted in any position. The unit should be mounted at least one inch from the exhaust pipes to avoid excess heat. The suggested location is ahead of the engine at the top of the down tubes. Make sure the mounting location does not interfere with the normal operation of the motorcycle.

To mount the MC-3, use it as a template and mark the mounting hole locations. Drill the four holes using a 3/16" drill and install four vibration mounts and the MC-3.

## WIRING

### WIRE FUNCTIONS

The following chart describes what each wire of the MC-3 is used for.

RED	Connects directly to the battery positive (+) terminal or starter solenoid 12 volt terminal.
BLACK	Connects to the battery negative (-) terminal or the engine ground.
GRAY	Connects to switched 12 volt side of ignition switch. It switches the input voltage from the RED wire on and off.
WHITE	Connects to the "COIL A" trigger wire from the points or electronic amplifier (triggers the PURPLE and BLACK wire coil).
GREEN	Connects to the "B COIL" trigger wire from the points or electronic amplifier (triggers the ORANGE and YELLOW wired coil).
BROWN	Shift Interrupt wire interrupts the ignition output when applied to ground.
LIGHT BLUE	Activates the low rpm module when connected to ground.
SHORT BLUE LOOP	Cylinder select wire loop.

The following groups of two wires connect to the same components in different applications.

PURPLE BLACK	Connects to the front coil, "COIL A" terminals. One to coil negative, the other to positive. It does not matter which wire.
ORANGE YELLOW	Connects to the back coil, "COIL B" terminals. One to coil negative, the other to positive. It does not matter which wire.

## WIRING TO THE STOCK IGNITION SYSTEM

**Note:** The MC-3 will not work with Capacitive Discharge Ignitions or 4-cylinder engines with an individual coil per cylinder. The Yamaha V-Max is one bike that cannot accept an MC-3.

**Note:** The factory rev limiter and timing curve will still function with the MSD installed. To disable the factory rev limiter and timing curve an aftermarket stand alone trigger amplifier is required.

1. Locate the ignition coils and identify which side of the coil(s) has 12 volts going to it. If the polarity of the coil is not identified, follow this procedure (Figure 2):
  - A. Disconnect the coil wires and remove them from the terminals.
  - B. Using a voltmeter connected to one wire and to ground, turn the ignition to the On position and check for 12 volts. **Note:** Make sure the wires do not make contact with any engine components.

C. The wire that shows 12 volts is the positive side. Turn the ignition Off and mark that coil wire as positive and the other as negative. If necessary, mark which wires go to Coil A and Coil B.

**Note:** If 12 volts is not present on either coil wire the motorcycle may have a Capacitive Discharge Ignition and cannot use an MSD MC-3.

2. At this point, all of the coil wires should be marked with its polarity and which coil (A or B) the wires connect to.

**Single Coil:** Attach the coil's negative wire to the White wire of the MSD (Figure 3).

**Dual Coils:** Attach the Coil A negative wire to the White wire of the MSD and the Coil B negative wire to the Green wire of the MSD (Figure 4).

3. Connect the MSD Gray wires to the coil(s) positive wires.

**Note:** The MSD has two Gray wires and it doesn't matter which wire(s) connect to which coil in dual coil applications. For single coil installation, connect both Gray wires to the original coil positive wire. These wires provide a switched 12 volt source to turn the MSD on and off.

4. The following wires connect directly to the coil terminals. The MSD Black and Purple wires connect to Coil A. The Orange and Yellow wires attach to Coil B. It does not matter which side of the coil the wires connect to. If you only have a single coil, seal the ends of the Orange and Yellow wires.

5. Review your wiring with Figure 3 or 4 and make any corrections. If everything matches, connect the heavy Red wire to the battery positive (+) terminal and the heavy Black wire to the negative (-) battery terminal. The wiring is complete.

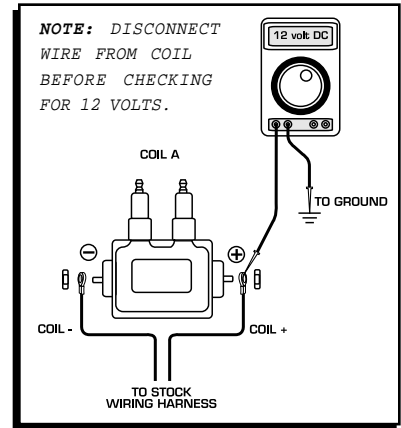

**Figure 2 Checking for Coil Wire Polarity.**

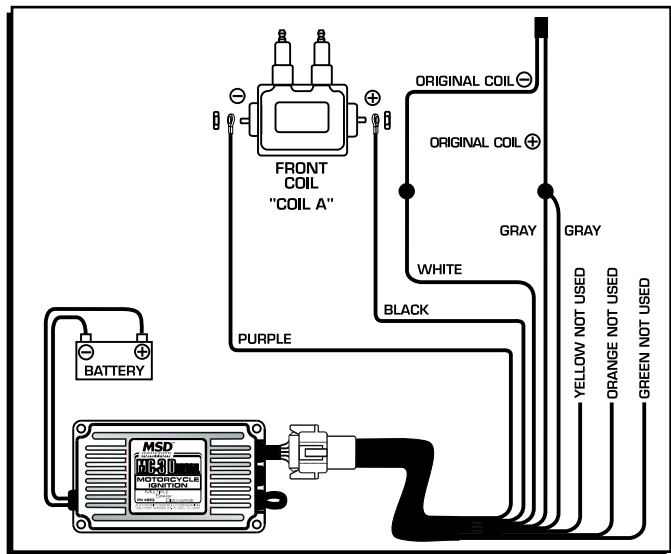

**Figure 3 Wiring to a Stock Single Coil System.**

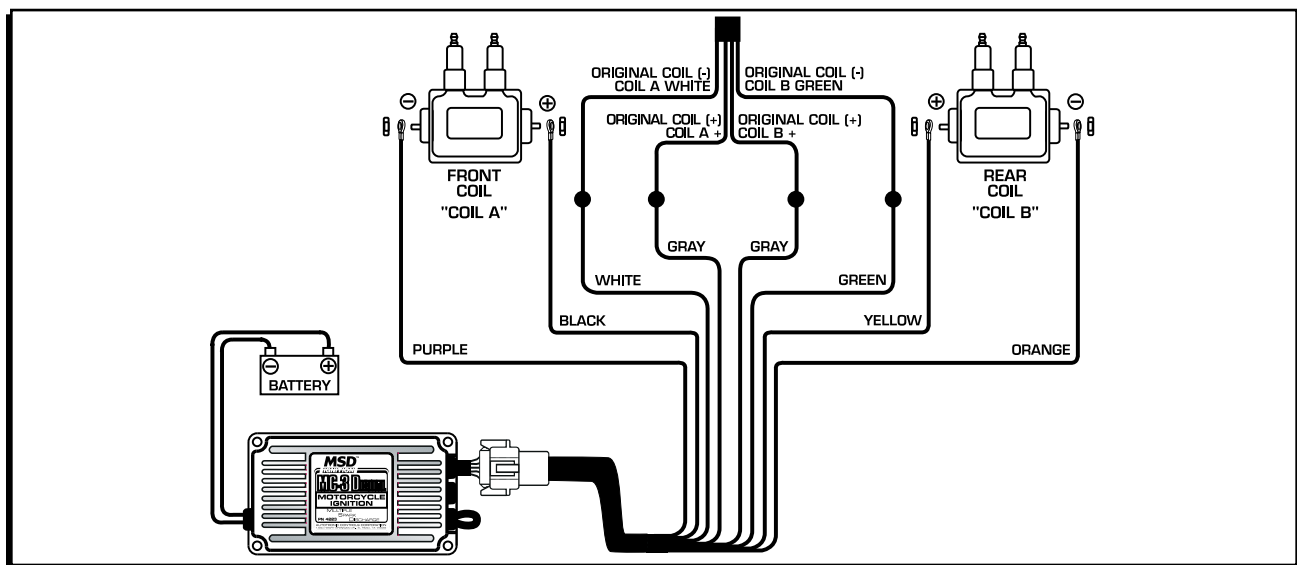

**Figure 4 Wiring to a Stock Dual Coil Ignition System.**

## AFTERMARKET AMPLIFIER TRIGGER

By using an aftermarket trigger system on some bikes, the factory timing curve and rev limit may be bypassed. Use the same wiring procedure as described in the Wiring to a Stock Ignition section. Figures 5 and 6 show a typical aftermarket amplifier trigger.

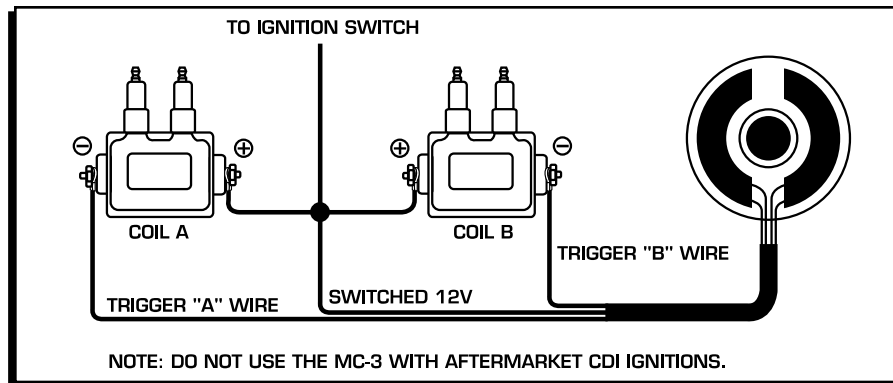

**Figure 5 Typical Aftermarket Amplifier Trigger without MC-3.**

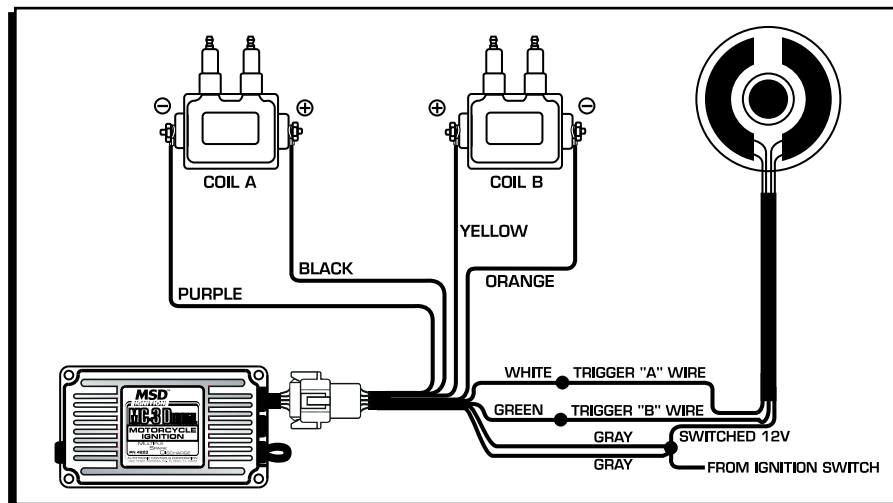

**Figure 6 Wiring the MC-3 to an Aftermarket Amplifier Trigger.**

## INITIAL START-UP

Before starting the engine, review the wiring steps and make sure all of your connections are tight and secure. Make sure the spark plug wires are installed and the battery terminals are tight then start the engine.

If the engine runs a short time then stalls, the engine may be equipped with an electric fuel pump relay and might require an MSD Tach Adaptor, PN 8920. Contact MSD for information. After wiring the MC-3, take time to review these steps.

- The only wires on the coils should be the PURPLE-BLACK and ORANGE-YELLOW wires. **DO NOT hook any other wires to the coils.**
- The GRAY wires should be connected to a switched 12 volt source, allowing the system to be turned on and off by the ignition switch.

**TACH ADAPTER INSTALLATION**

If the engine started then stalled within a couple of minutes, you will have to install an MSD Tach Adapter, PN 8920. The cause for this is due to the fuel pump not receiving a strong enough trigger signal through the MSD. The Tach Adapter ensures that the fuel pump receives a strong trigger signal (Figure 7).

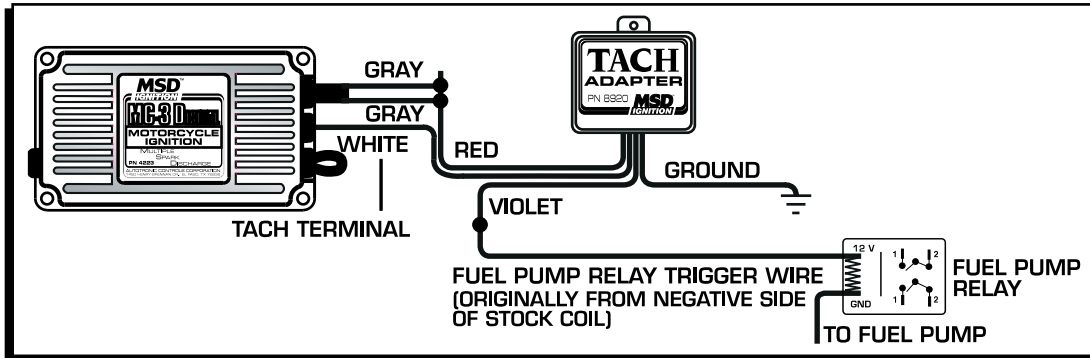

Figure 7 Installing an MSD Tach Adapter.

**TACHOMETER OUTPUT**

The MC-3 Ignition has a built-in tach output terminal (Figure 8). This terminal will directly drive many models of tachs. The output combines both input signals from either the points or electronic ignition amplifier into one signal. Due to this, it is possible for some tachs to read double the engine rpm. If the rpm reading is doubled when using the tach output terminal, splice the tach wire into either the WHITE or the **single** GREEN wire.

**SHIFT LIGHT**

A Shift Light can easily be connected to the MC-3. Figure 8 shows a common setup with an MSD Shift Light.

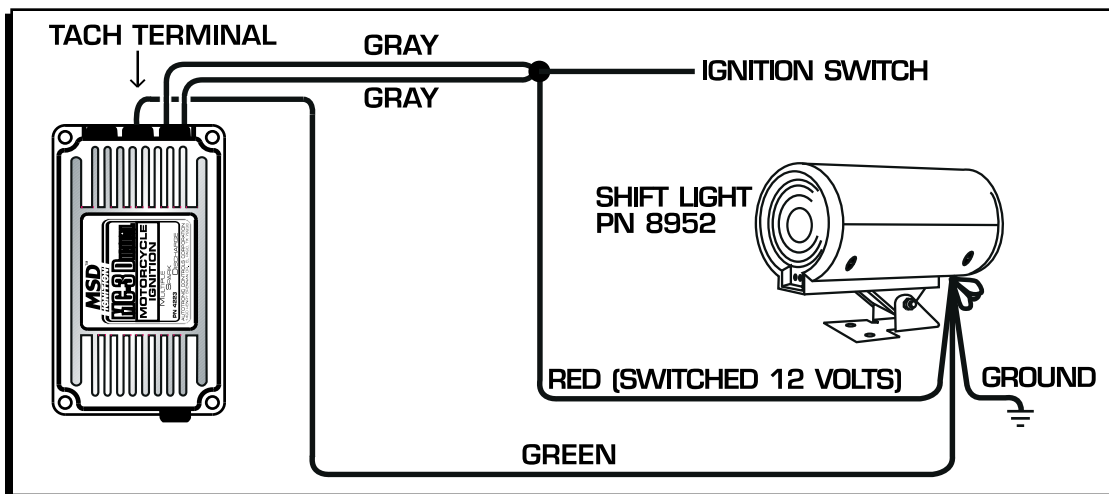

Figure 8 Wiring an MSD Shift Light.

**PROGRAMMING**

**SHIFT "INTERRUPT" FEATURE**

The MC-3 Ignition has a special Shift "Interrupt" feature. When applied, the ignition output will be interrupted thereby unloading the transmission and allowing the shift to occur. This system is different than normal ignition "kills" which simply interrupt the power to the coils causing a spark to occur at the time the switch is released which may result in severe backfires.

The MC-3 Interrupt feature only operates in the output section of the ignition, allowing all of the timing functions to keep operating properly. This ensures that no backfires will occur.

To incorporate the Interrupt feature, connect the BROWN wire of the MC-3 to the Normally Open (NO) terminal of the Shift "Kill" switch. Wire the common (C) terminal of the switch to ground (Figure 10).

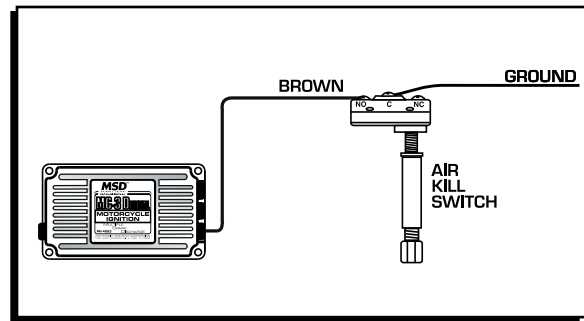

Figure 10 Wiring the Air Shift Interrupt Feature.

**THE TWO STEP MODULE**

The Two Step feature of the MC-3 provides the capability of switching between two rpm limits that are set using plug-in modules.

To use the Two Step feature, connect the LIGHT BLUE wire to a switched ground (see Figure 11). When the LIGHT BLUE wire is grounded, the Low module is engaged. When the LIGHT BLUE wire is not grounded (open), the High module is engaged. Choose the rpm module you wish to set at low rpm and insert it in the "LOW" module holder. Insert the high rpm module, for over-rev protection, in the "HIGH" holder.

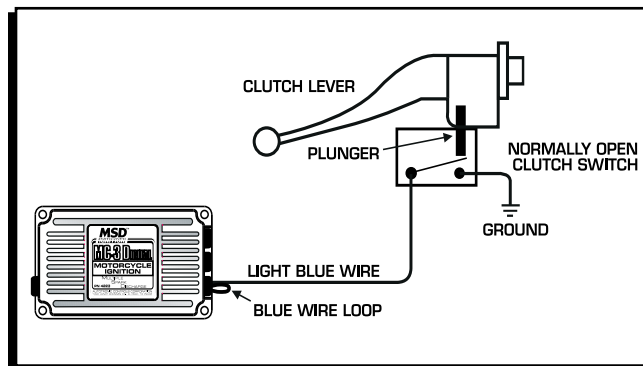

Figure 11 Wiring the Two Step Module Selector.

MSD offers additional rpm modules in sets of five, or an adjustable module selector. The module selector is an adjustable knob that provides several rpm settings for even easier adjustment. The module kits come in increments of 200 rpm within a range of 1,000 rpm.

PN	RPM	MODULES	PN	RPM	MODULES
8743	3000	3200 3400 3600 3800	8749	9000	9200 9400 9600 9800
87431	3100	3300 3500 3700 3900	87491	9100	9300 9500 9700 9900
8744	4000	4200 4400 4600 4800	8750	10000	10200 10400 10600 10800
87441	4100	4300 4500 4700 4900	87501	10100	10300 10500 10700 10900
8745	5000	5200 5400 5600 5800	8751	11000	11200 11400 11600 11800
87451	5100	5300 5500 5700 5900	87511	11100	11300 11500 11700 11900
8746	6000	6200 6400 6600 6800	8852	12000	12200 12400 12600 12800
87461	6100	6300 6500 6700 6900	88521	12100	12300 12500 12700 12900
8747	7000	7200 7400 7600 7800	8853	13000	13200 13400 13600 13800
87471	7100	7300 7500 7700 7900	88531	13100	13300 13500 13700 13900
8748	8000	8200 8400 8600 8800			
87481	8100	8300 8500 8700 8900			
PN	RPM	SELECTORS	PN	RPM	SELECTORS
8670		3000 - 5200	8673		7600 - 9800
8671		4600 - 6800	8674		9000 - 11200
8672		6000 - 8200	8675		10600 - 12,800

**RETURNING TO STOCK IGNITION**

To return the ignition system back to standard operation (points and standard electronic trigger systems only) simply unplug the MC-3 control cable and insert the jumper plug (supplied) into the cable connector. If using high performance, low resistance coils, a 1.5 ohm ballast must be wired into the GRAY wire going to the positive (+) side of the coil (Figure 12).

**Note:** In the event of having to run the motorcycle without a battery, unplug the MC-3 and return to standard operation. Operating without a battery could cause severe damage to the MC-3.

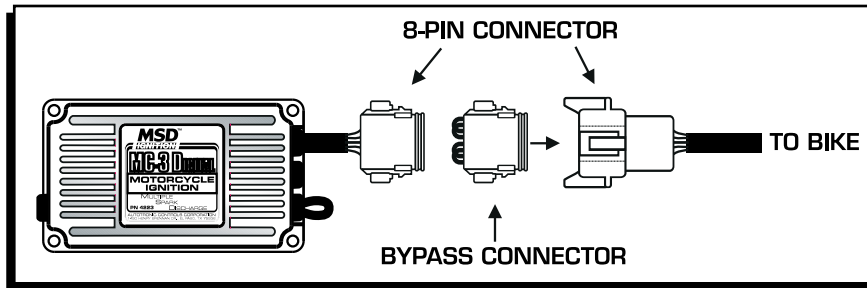

**Caution:** If using MSD pickup triggers, **DO NOT USE** the bypass connector. The coils will be damaged.

**Figure 12 Bypassing the MSD MC3.**

**TROUBLESHOOTING**

**WIRING CHECK**

**WARNING:** The MC-3 produces very high voltages. Never short the battery or coil terminals. Use caution when checking connections and while troubleshooting.

- Check all of the wiring connections making sure they are clean and tight. If connectors have been crimped on make sure they are tight and sealed.
- Confirm that the battery is fully charged and properly connected. Also check that the MSD power leads are connected properly and are tight.
- Check that the only wires connected to the coil(s) are from the MSD.
- After checking the wiring for loose or faulty connections, follow the next procedure to confirm that the MSD is “sparking” properly.

**WARNING:** Do not connect any test equipment to the coil terminals.

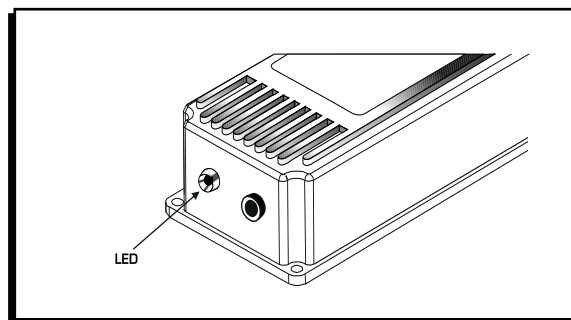

**Figure 13 LED Monitor.**

**LED MONITOR**

The MC-3 is equipped with an LED monitor (Figure 13). The LED will light every time there is a spark. At above idle engine speeds, it may appear to be on continuously. Also, the static timing can be checked and adjusted by watching for the LED to light.

If the LED begins flashing erratically, it is indicating a problem. The battery may be getting too low for full power operation, or a coil positive wire may be grounded.

# **MSD** **IGNITION** **INSTALLATION INSTRUCTIONS**

## **CHECKING FOR SPARK**

The following procedure will determine if the ignition is producing a spark.

1. With the ignition Off, remove one of the plug wires from the spark plug. Use a spark tester tool (such as the ST 125) or position the wire so the terminal is about 1/2" from ground.
2. Disconnect the White wire of the MSD.
3. Turn the ignition On. **DO NOT CRANK THE ENGINE.**
4. Tap the White wire to ground several times. A spark should jump to ground when the wire is removed from ground. If it sparks, the ignition is operating properly. Repeat the procedure with the Green wire if your engine has two coils.
5. **No Spark:** Substitute another coil and test again. If there is still no spark and all of the wiring and connections have been inspected and confirmed, contact the MSD Customer Service Line to send the unit in for repair.

## **CHECKING THE COIL**

Using an Ohm meter, you can check the resistance of the coil(s). The following specifications are for MSD's PN 8204 Motorcycle Coil. Check your Service Manual for stock coil specifications. If either measurement is out of specification the coil must be replaced.

**Primary Resistance:** Check the resistance between the positive and the negative terminals. It should be 1.2 - 1.4 ohms.

**Secondary Resistance:** Check the resistance between the spark plug terminals. It should be 11,000 - 11,500 ohms (11K - 11.5K).

### **Service**

In case of malfunction, this MSD component will be repaired free of charge according to the terms of the warranty. When returning MSD components for service, Proof of Purchase must be supplied for warranty verification. After the warranty period has expired, repair service is charged based on a minimum and maximum charge.

Send the unit prepaid with proof of purchase to the attention of: **Customer Service Department, Autotronic Controls Corporation, 12120 Esther Lama, Suite 114, El Paso, Texas 79936.**

When returning the unit for repair, leave all wires at the length in which you have them installed. Be sure to include a detailed account of any problems experienced, and what components and accessories are installed on the vehicle.

The repaired unit will be returned as soon as possible after receipt, COD for any charges. (Shipping is covered by warranty). All units are returned regular UPS unless otherwise noted. For more information, call the MSD Customer Service Line (915) 857-5200. MSD technicians are available from 8:00 a.m. to 5:00 p.m. Monday - Friday (mountain time).

### **Limited Warranty**

Autotronic Controls Corporation warrants MSD Ignition products to be free from defects in material and workmanship under normal use and if properly installed for a period of one year from date of purchase. If found to be defective as mentioned above, it will be replaced or repaired if returned prepaid along with proof of date of purchase. This shall constitute the sole remedy of the purchaser and the sole liability of Autotronic Controls Corporation. To the extent permitted by law, the foregoing is exclusive and in lieu of all other warranties or representations whether expressed or implied, including any implied warranty of merchantability or fitness. In no event shall Autotronic Controls Corporation be liable for special or consequential damages.