

DYNA III ELECTRONIC IGNITION INSTALLATION INSTRUCTIONS

PART NO.D31-1 FOR HONDA 350/400 FOUR CYLINDER MOTORCYCLES
PART NO. D31-2 FOR HONDA 500/550/750 FOUR CYLINDER MOTORCYCLES

The DYNA III Electronic Ignition System was designed as a high performance points replacement. It was designed for use with stock, or other coils that have at least THREE OHMS primary resistance.

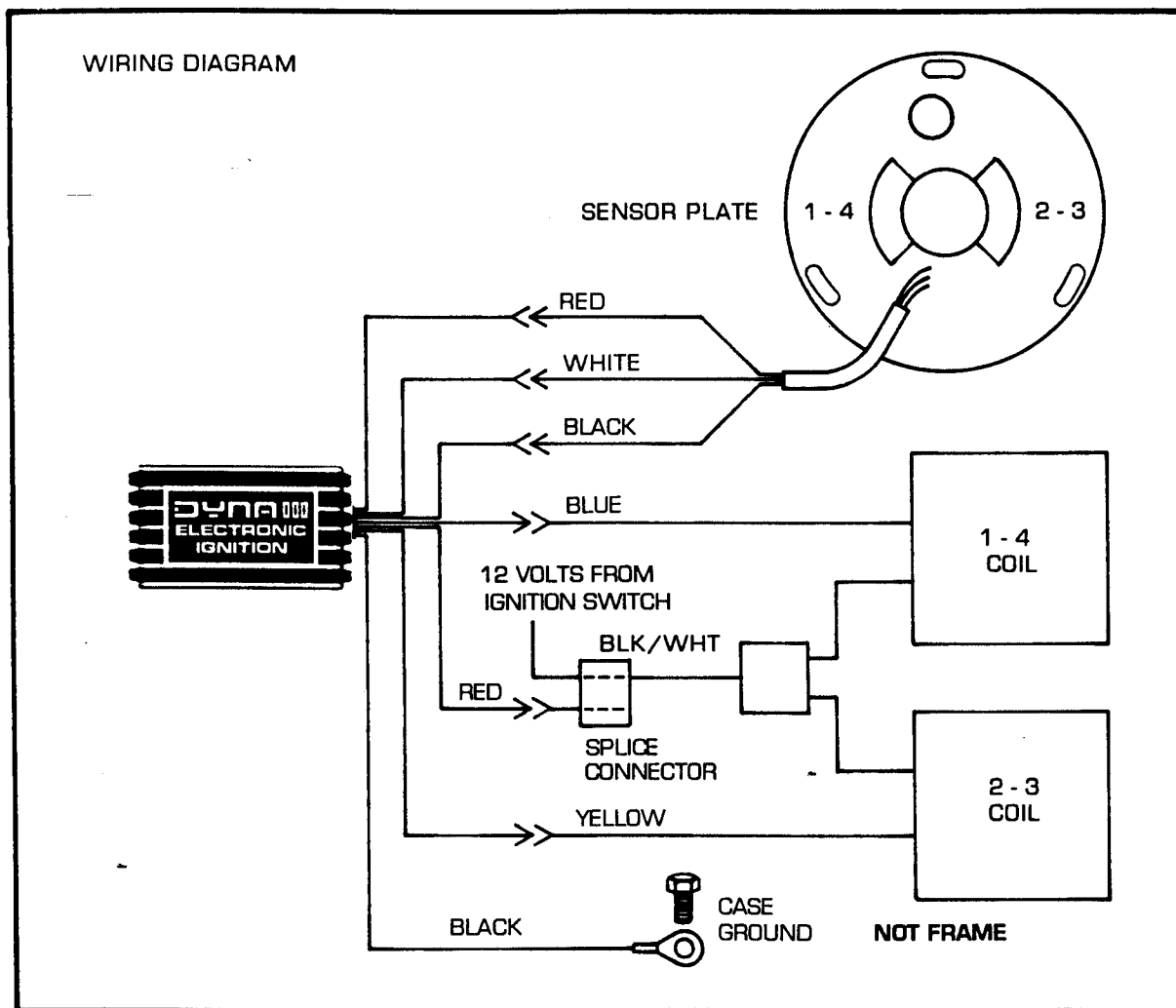

PROCEDURE-

- 1) Fasten the clamp to the electronic module using the 4-40 x 5/16 screws and locknuts provided. The clamp and nuts go on the inside of the case.
- 2) Attach the module to the frame in the location selected. Cut off excess clamp material.
- 3) Remove an engine case bolt and fasten the ground lug (black wire) securely to the engine. **DO NOT ATTACH TO FRAME.**
- 4) Remove the fuel tank. Locate the two ignition coils. There is a black/white wire coming from each coil to a common junction in the wire harness. These wires carry the switched 12 volts to the coils. Using the splice connector provided, (FIGURE 2) attach the separate red wire included in the kit to the black/white wire that goes to the coils. Do not strip the wires when using the splice connector. Use pliers to push the clip down.

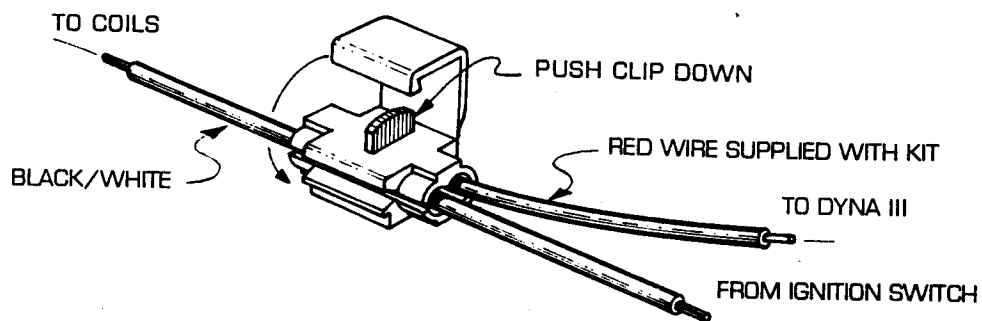

FIGURE 2

- 5) Plug the red wire coming from the electronic module into the red wire installed in Step 4.
- 6) Remove the point cover.
- 7) Remove the 10 mm nut or bolt (depending on model), and hex washer holding the spark advance assembly to the engine.
- 8) Remove the three screws holding the point plate to the engine. Disconnect the blue and yellow point wires where they plug into the wire harness and remove the entire point/plate assembly.
- 9) Remove the spark advance assembly from the engine.

- 10) Remove the point cam from the advance assembly by twisting to the right and pulling.
- 11) On some 550 and 750 models, a small pin will be seen projecting from the 1 - 4 side of the advance assembly shaft. This pin must be removed, and can be, by gently tapping on the side of the pin with a screwdriver and hammer.
- 12) Coat the advance assembly shaft lightly with oil. While holding it with the 1 - 4 side pointing up, slip the DYNA III rotor over the shaft. A slight indentation approximately 1/4 inch in diameter will be noticed on one side of the rotor. This indentation must face to the left when the 1 - 4 on the advance assembly is pointing up. Push the rotor down until it engages the weights on the advance assembly. Ensure that the rotor rotates freely on the shaft as the advance weights move out and back.
- 13) Install the advance/rotor assembly on the engine making sure the pin on the advance assembly is engaged in the pin hole in the crankshaft. Reinstall the hex washer and 10 mm nut or bolt, and tighten. Ensure that the rotor is still free to rotate.
- 14) Install the DYNA III sensor plate using the three screws previously removed, and tighten.
- 15) Route the cable out of the hole or slot in the engine case and over to the electronic module, being careful to avoid the exhaust system. The grommet from the point cable may be used by slitting it with a razor blade to remove it.
- 16) Connect the three plugs to the receptacles, matching the red, white, and black wires.
- 17) The electronic module mounting site will determine how the remaining blue and yellow wires are connected. If the unit is mounted on the side of the bike, the wires are plugged into the receptacles where the original points connected. If the unit is mounted at the front of the bike, or under the tank, the blue and yellow wires going into the ignition coils are unplugged and replaced with those coming from the module.
- 18) This completes the wiring. Make sure that all connections are secure and that all colors match.

TIMING-

NOTE:

- A) The left sensor triggers cylinders 1 - 4, the right sensor triggers cylinders 2 - 3 and each provides $\pm 10^\circ$ of adjustment. Moving them counterclockwise advances the timing and clockwise movement retards the timing.

TIMING CONTINUED-

- B) Ground circuit on back of sensor plate must be in contact with engine in order for ignition to operate.
 - C) All timing adjustments should be made using the advance timing marks which are approximately 1/2 inch to the right of the F marks on the advance assembly.
 - D) The sensor to rotor air gap is not critical as long as there is no contact between the parts. There should generally be .020 to .040 inch between them.
- 1) To time the engine statically, connect a 12 volt test light from the junction of the blue coil wires to ground (engine case). Do not disconnect the wires. Use a wrench on the advance assembly hex washer to rotate the engine.
 - 2) Turn ignition switch on. While holding the rotor in the fully advanced position (clockwise), slowly rotate engine forward until the test light turns on. The right hand advance mark for cylinders 1 - 4 should align with the fixed mark on the engine case. If it does, proceed to Step 5.
 - 3) If the marks do not align, loosen the nuts on the left sensor and move it clockwise or counterclockwise as appropriate (.010 inch equals 1°) and gently retighten nuts.

NOTE: If light remains bright at all times, it indicates that there is a bad connection in the wiring. Ensure that there is 12 volts to the red module wire.

- 4) Rotate the engine backwards until the light goes out, and repeat Steps 2 and 3.
- 5) After 1 - 4 timing is verified, connect the test light to the yellow coil wire. Repeat Steps 2, 3 and 4 using the 2 - 3 timing marks and the right sensor block.
- 6) The engine can also be timed dynamically using a strobe light in the normal manner. Use the advance marks and an engine speed of about 2500 RPM (full advance).
- 7) Replace timing cover and fuel tank.

DYNATEK
164 S. VALENCIA ST.
GLENORA, CA 91741
(626) 963-1669
FAX (626) 963-7399