

MSD **IGNITION** **INSTALLATION INSTRUCTIONS**

MSD Universal Motorcycle Trigger Pickups PN 42306

IMPORTANT: Read These Instructions Before Attempting The Installation!

CAUTION: This pickup assembly is for use with an MSD Motorcycle Ignition **only**.
Do Not connect directly to coils or failure of the pickup will result.

Parts Included In This Kit

2 - Trigger Pickups

1 - Magnet

1 - Parts Bag

WARNING: During installation, disconnect the battery cables. When disconnecting the battery, always remove the Negative cable first and install it last.

Note: The MSD Motorcycle Trigger Pickup will eliminate all timing advance functions unless used with a mechanical advance mechanism.

The Universal Motorcycle Triggers can be used with the MSD MC-3 or MC-4 Ignition Controls. The triggers are supplied with the wiring harness, mounting screws and magnet.

FABRICATION REQUIRED

This is a universal kit so a mounting plate and rotor will need to be fabricated. In most cases, the two pickups need to be mounted 180° apart. The magnet will need to be installed to the rotor in line with the pickups.

WIRING

Clean, well crimped or soldered connections ensure reliable operation of the ignition system. Before making any connections, inspect all wires and their routing. Figure 1 shows the proper connections for the MSD Trigger Pickup Assembly.

Trigger Pickups	4 Pin Connector
Red	+12V to Trigger Pickups
Black	Ground to Trigger Pickups
White (Coil 1)	This wire connects to Channel #1 of the ignition.
Blue (Coil 2)	This wire connects to Channel #2 of the ignition.

SETTING THE TIMING

In order to set your timing your mounting plate will have to have slots in order to rotate the plate clockwise or counterclockwise. In most cases moving the plate counterclockwise advances the timing and clockwise retards the timing. This will also depend on the rotation of your engine. The pickups are also slotted to equalize timing between cylinders.

MAGNET

Note: The rotor must be made out of aluminum.

In the rotor that was fabricated a hole will have to be drilled approximately 1/4" in diameter and 1/4" in depth. The magnet should sit flush with the outer diameter of the rotor, with marked side of the magnet facing out. To secure the magnet in place use JB Weld or equivalent epoxy.

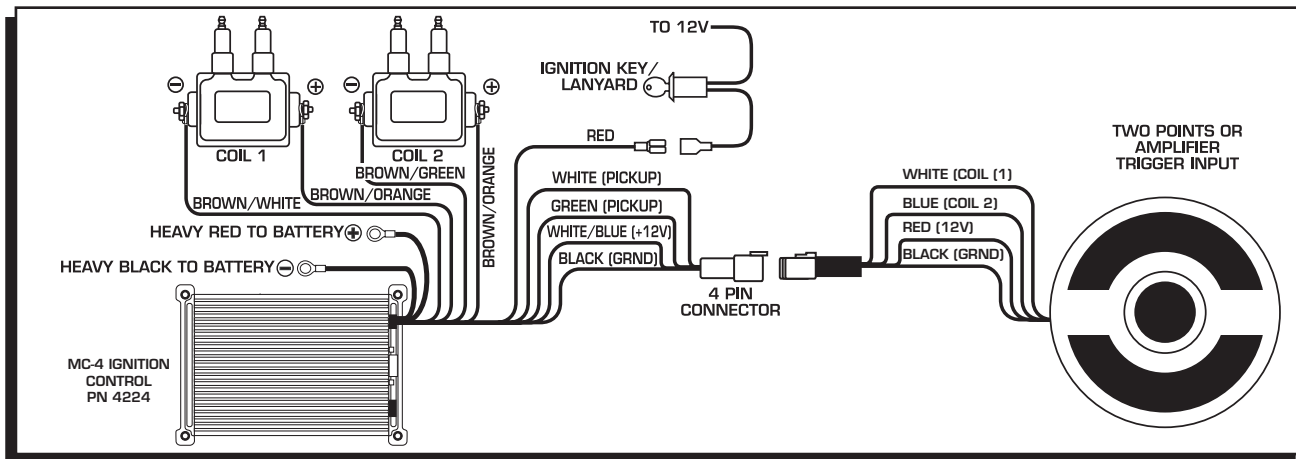

Figure 1 Wiring the MSD Trigger Pickup.

Service

In case of malfunction, this component will be repaired free of charge according to the terms of the warranty. When returning components for service, Proof of Purchase must be supplied for warranty verification. After the warranty period has expired, repair service is charged based on a minimum and maximum charge.

All returns must have a Return Material Authorization (RMA) number issued to them before being returned. To obtain an RMA number please contact MSD Customer Service at (915) 855-7123 or fax a request to (915) 857-3344. Send the unit prepaid with proof of purchase to the attention of: **MSD Powersports, Customer Service - RMA #, 12120 Esther Lama, Dock 5, El Paso, Texas 79936.**

When returning the unit for repair, leave all wires at the length in which you have them installed. Be sure to include a detailed account of any problems experienced, and what components and accessories are installed on the vehicle.

The repaired unit will be returned as soon as possible after receipt, COD/Cashiers Check for any charges. For more information, call the MSD Powersports Customer Service Line **(915) 858-3365**. MSD Powersports technicians are available from 8:00 a.m. to 5:00 p.m. Monday - Friday (Mountain Time).

Limited Warranty

MSD Powersports warrants this product to be free from defects in material and workmanship under its intended normal use* and if properly installed, for a period of one year from the date of original purchase. If found to be defective as mentioned above, it will be repaired or replaced at the option of MSD Powersports. Any item that is covered under this warranty will be returned free of charge through standard shipping methods. If faster service is required the customer has the option of paying for this service.

This shall constitute the sole remedy of the purchaser and the sole liability of MSD Powersports. To the extent permitted by law, the foregoing is exclusive and in lieu of all other warranties or representations whether expressed or implied, including any implied warranty of merchantability or fitness. In no event shall MSD Powersports or its suppliers be liable for special or consequential damages.

*Intended normal use means that this item is being used as was originally intended and for the original application as sold by MSD Powersports. Any modifications to this item or if it is used on an application other than what MSD Powersports markets the product, the warranty will be void. It is the sole responsibility of the customer to determine that this item will work for the application they are intending. MSD Powersports will accept no liability for custom applications.