



WIDE OPEN THROTTLE/ RPM ACTIVATED 2 STAGE WINDOW SWITCH WITH SHIFT LIGHT CONTROL

Kit Number 15982NOS



OWNER'S MANUAL
P/N 199R10482

CONGRATULATIONS on purchasing your NOS WOT/Window Switch! It should provide many miles of trouble-free performance when used correctly. If you have any questions regarding the performance of your system, call NOS Technical Service at 1-866-GOHOLLEY or refer to the tech section of our website at: www.holley.com.

NOTICE: Installation of Nitrous Oxide Systems Inc. products signifies that you have read this document and have agreed to the terms stated within.

It is the purchaser’s responsibility to follow all installation instruction guidelines and safety procedures supplied with the product as it is received by the purchaser to determine the compatibility of the product with the vehicle or the device the purchaser intends to install the product on.

Nitrous Oxide Systems Inc. assumes no responsibility for damages occurring from accident, misuse, abuse, improper installation, improper operation, lack of reasonable care, or all previously stated reasons resulting from incompatibility with other manufacturers’ products.

Nitrous Oxide Systems Inc. assumes no responsibility or liability for damages incurred by the use of products manufactured or sold by Nitrous Oxide Systems Inc. on vehicles used for competition or racing.

Nitrous Oxide Systems Inc. neither recommends nor condones the use of products manufactured or sold by Nitrous Oxide Systems Inc. on vehicles, which may be driven on public roads or highways, and assumes no responsibility for damages incurred by such use.

NOS nitrous oxide is legal for use in most states when used in accordance with state and local traffic laws. NOS does not recommend or condone the use of its products in illegal racing activities.

NOS has not pursued California Air Research Board (CARB) exemptions for these kits, hence, they are not legal for use on pollution-controlled vehicles in California. A correctly installed NOS nitrous system should not alter the emission control performance of your vehicle under standard EPA test cycle conditions.

TABLE OF CONTENTS

Chapter 1 Kit Components	2
Chapter 2 Kit Installation	2
2.1 NOS WOT/Window Switch.....	2
2.2 Electrical Installation	3
2.3 RPM Input Connection:	4
2.4 Testing The Throttle Position Sensor:	4
2.5 Configuring Settings of the NOS WOT / Window Switch.....	5
2.6 Verifying Settings and Operation of the NOS WOT / Window Switch	7

Chapter 1 Kit Components

200R544A	WOT / Window Switch	Qty. 1
204R247	T-tap Crimp Connectors	Qty. 2
204R307	Male Disconnects	Qty. 2

Chapter 2 Kit Installation

2.1 NOS WOT/Window Switch

The NOS WOT/RPM activated 2 stage Window Switch with Shift light control is a universal activation switch. It is designed to work with 4-cycle engines ranging from 1 to 18 cylinders. Activation of output wires is determined by engine RPM speed input and/or Throttle Position Sensor (TPS) input. Use of an RPM and TPS input ensures safe operation of a nitrous system by only allowing for activation at wide-open throttle and above a safe engine speed and is highly recommended.

The TPS portion of the switch works by recognizing what voltage the TPS sensor is outputting to the vehicle’s ECU. This is particularly useful on late model electronic/”drive-by-wire” throttle body equipped vehicles. Typically, wide open throttle is achieved at around 4 volts or above on most TPS equipped vehicles. The NOS WOT/Window switch can be set to various voltages for the TPS activation. This switch is compatible with both rising and falling throttle position sensors. NOS recommends that this be set to a voltage at or just below TPS “W.O.T.” voltage.

Some drive-by-wire vehicles such as GM LS2 engines use a “falling” TPS voltage, meaning that as the throttle is opened voltage decreases compared to typical applications which use a “rising” TPS voltage meaning that as the throttle is opened the voltage increases. This unit can work with either a rising or falling TPS voltage.

The RPM input can be connected to an individual ignition coil “driver” wire or to a tachometer output circuit. (Information on this connection is contained further in the manual.)

This unit is aesthetically designed so that it can be mounted in the passenger compartment. The user can then view engine speed, TPS position, and nitrous arming and activation information, as well as make easy changes to the unit. It can be used to troubleshoot any issues with system activation as well.

If you have any questions, please contact **NOS tech service at 1-866-GOHOLLEY**.

WARNING: Improper wiring of this unit may cause damage

2.2 Electrical Installation

Refer to **Figure 1** and the procedures in this section for NOS electrical system installation.

WARNING! Death or injury may occur from working on a charged electrical system.

1. Disconnect the car battery at the ground cable (if not already done).
2. Install the WOT/Window Switch as follows:
 - A. Find a suitable mounting location away from heat and vibration (ex. Firewall or vehicle interior). Position so that the wires are pointing down if mounted in engine compartment. Although the unit is potted, it should not be placed in such a way that it will receive a heavy spray of water.
 - B. Loosely route the WOT/Window Switch wires to the locations found on the drawing.
 - C. Route the Red / White wire from the WOT/Window Switch to the nitrous arming switch.
3. When installing the WOT/Window Switch, place the NOS relay (Part # 15618NOS, Sold separately) in the engine compartment near the battery. The orange wire on the relay harness should reach the positive terminal of the vehicle battery.
4. Connect the orange relay wire to the battery (+) terminal. Install a 15 AMP fuse into the fuse socket.
5. Connect one wire from each solenoid together and attach to the blue relay wire (trigger).

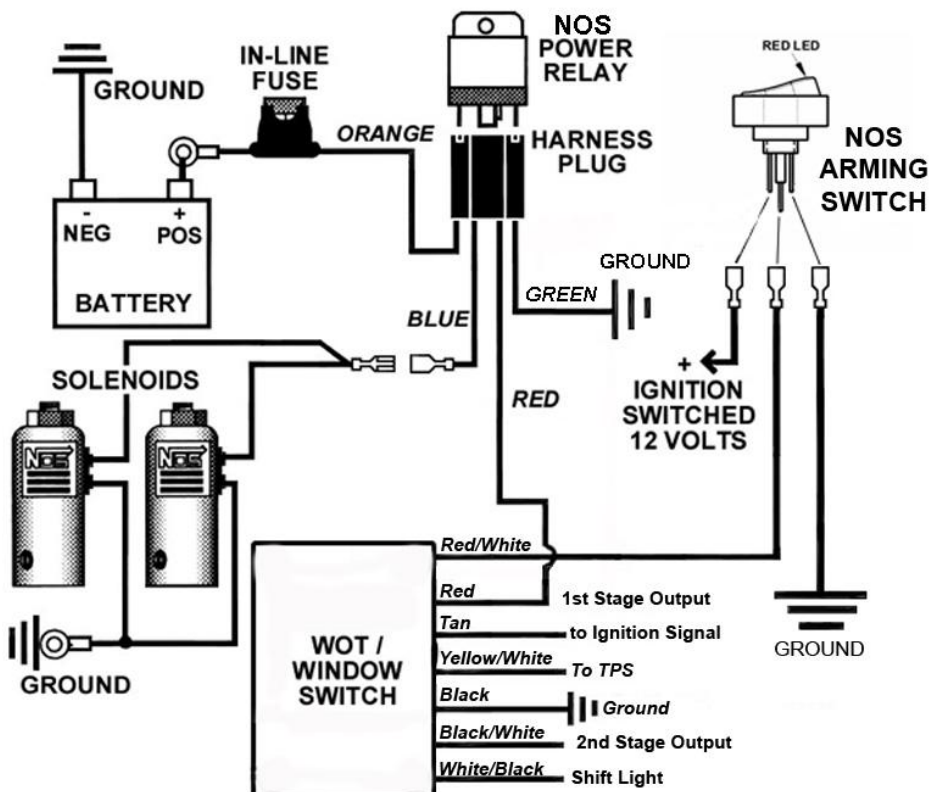

Figure 1 Electric Wiring Schematic for NOS Relay and NOS WOT/RPM Switch ONLY

6. Connect the remaining solenoid wires to good chassis ground.
7. Ground the green relay wire to a good chassis ground.
8. Connect red relay wire to the solid red wire (power +12V side of relay) on the WOT/Window Switch.
9. Connect the tan wire of the WOT/Window Switch to the ignition coil signal wire or tach output wire using the T-tap provided, as shown in **Figure 2**. See **Section 2.3**.

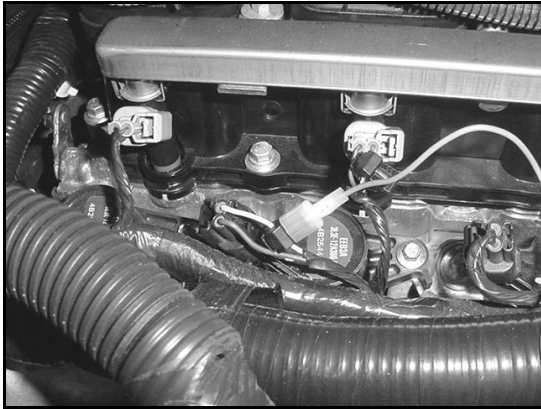

Figure 2

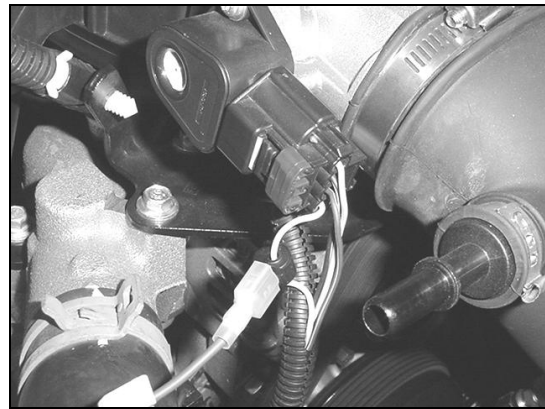

Figure 3

10. Connect the black wire of the WOT/Window Switch to a good ground.
11. Connect the yellow / white striped wire on the WOT/Window Switch using a T-tap (provided) to the vehicle's TPS reference signal wire (typically "TP sensor signal" in the factory service manual). **See Figure 3**. For help identifying proper wire, **see Section 2.4**.
12. Connect the red / white striped wire on the WOT/Window Switch to the middle or #2 terminal of the NOS arming switch (not supplied with this kit).
13. Connect the #1 terminal (away from the LED) of the NOS arming switch to a 12 volt switched power source in the car. Connect the #3 terminal (side of the LED) to a ground.
14. The black/white striped wire is for a second stage of control. An example of its use can be a 2nd stage of nitrous control. This stage is a ground output and must be connected to the **GREEN** ground wire of a second relay (Part # 15618NOS, Sold separately). The solid red wire from the relay should be wired to the center terminal of the NOS arming switch. Wire the remainder of the relay wires according to the illustration and steps 3 thru 7 above. If this wire will not be used, heat shrink the end and secure it tightly out of the way.
15. The white/black striped wire is the shift output. This wire is only capable of supplying a low current ground output. If using the black/white wire to trigger a high current device (over 1Amp), a relay **must** be installed and the white/black wire used to activate the low current side of the relay. If you need a +12v output trigger, use the white/black wire to activate a relay that will supply +12v. If this wire will not be used, heat shrink the end and secure it tightly out of the way.
16. Once these steps are verified, proceed to the next section.

2.3 RPM Input Connection:

The RPM input wire (Tan) can be connected to a square wave signal wire, found on most capacitive discharge ignition systems, or to a coil trigger wire on inductive ignition systems. The unit can be adjusted according to how many times per revolution the circuit is triggered. The wire needs to be connected to what is usually referred to as the "coil signal", "coil trigger", or "tach output" wire.

NOTE: If using a capacitive discharge ignition system, such as a MSD unit, **NEVER** connect to any of the coil wires or the unit will be damaged. You must connect to the "tach out" wire on the MSD unit.

NOTE: Always refer to the factory service manual to ensure you connect to the proper wire or damage will result.

2.4 Testing The Throttle Position Sensor:

A properly adjusted and functioning throttle position sensor is essential to the proper operation of the NOS WOT/Window Switch. The TPS is a precision electrical component that acts as a variable resistor. The ECU provides a reference voltage to the TPS. As the resistance varies with the throttle angle, the TPS provides a return signal to the ECU.

1. Locate the vehicle's TPS, and the associated wires that attach to it (refer to factory service manual).
2. Turn the ignition key to the "on" position.
3. Using the positive lead of the voltmeter, probe the wires that connect to the TPS sensor. On a drive-by-wire vehicle, the signal wire is usually termed "TP sensor signal". One wire will have a constant 5 volt signal to it (reference), the other wire will be a ground wire, and the remaining wire will be the signal wire (drive-by-wire throttle bodies usually have 2 signal wires).
4. When the "signal" wire is located, note the voltage that is output with the throttle closed. **(See Note)** This value will typically be 1 volt or less, depending on the application for rising TPS signals. If it is a falling TPS signal, this voltage is typically 4-5 volts at idle.

NOTE: Output voltage with the key on engine off of a drive by wire vehicle may be lower as these systems use the throttle plate to control idle air instead of an IAC.

5. Slowly open the throttle and observe the voltmeter's readout. On a drive-by-wire vehicle, have an assistant apply the throttle pedal. The voltage should increase smoothly from the closed throttle voltage to 4.0 to 5.0 volts at wide-open throttle or decrease to 1.0 to 2.0 volts at wide open throttle.
6. Connect the provided T-tap connector onto the signal wire.
7. Refer to **Section 2.5** for setting and verifying proper TPS setting for the unit. The setting used should be what the voltage is at WOT or 0.1-0.2 volts less on a rising TPS signals and 0.1-0.2 volts more on falling TPS signals.

NOTE: The throttle position sensor input does NOT have to be used. If this input is not used and is to be disabled, connect the TPS input wire (from the NOS WOT/Window Switch) to a good chassis ground. Select "falling" TPS in the configuration and set value to 4.0.

2.5 Configuring Settings of the NOS WOT / Window Switch

NOTE: Recommended initial settings for the NOS WOT/Window Switch are as follows; RPM - 3000 rpm (On) and 6000 rpm (Off). The TPS should be configured for the appropriate type of system (rising or falling voltage) with voltage set .2 volts lower than WOT voltage for rising voltage and .2 volts higher than WOT voltage for falling voltage systems. **Altering RPM On and Off settings can be beneficial to tailor nitrous delivery to your particular application.**

1. To enter configuration mode, turn power on to the NOS WOT/ Window Switch, press and hold both the #1 and #2 buttons for 1-2 seconds. The upper display will read "Set Up" and then "Prog" momentarily **See Figure 4** and then the lower display will display "1 On" . The upper display will show the activation On RPM for the first stage. **See Figure 5**



Figure 4



Figure 5

NOTE: On RPM is indicated by the corresponding blue LED being illuminated. Off RPM will be indicated by the LED being illuminated red.

2. Depress the #2 BUTTON to scroll through the "ON" RPM thousandths position numbers. Once you have selected the desired thousandths RPM, press the #1 BUTTON to move over to the hundredths position. Repeat the steps above to complete the "ON" RPM desired.
3. Once the "ON" RPM has been selected the blue LED will turn red. This indicates that you are now ready to set the "OFF" RPM setting. The procedure for selecting the desired "OFF" RPM will be identical to the "ON" RPM setting procedure.
4. Once the last digit of the "OFF" RPM has been set, press the #1 BUTTON to enter the 2nd stage set up mode and the lower screen will display "2 On". Repeat steps # 2 and # 3 to program the "ON" and "OFF" RPM for stage 2.

5. Once the last digit of the "OFF" RPM has been set for the 2nd stage, press the #1 BUTTON to enter the Shift Light set up mode. You can use this to light a shift light at a given programmable RPM. The lower screen will display "Shft". Depress the #2 BUTTON to scroll through the RPM thousandths position numbers. Once you have selected the desired thousandths RPM, press the #1 BUTTON to move over to the hundredths position. Repeat the steps above to complete the Shift RPM desired. Once the last digit has been set, Press the # 1 button to enter the TPS mode.
6. The TPS mode will require the user to select either "rising" throttle position voltage or "falling" throttle position voltage. "Rising" throttle position voltage mode can be identified by the green flashing center LED. Press the #2 BUTTON once to select "falling" throttle position voltage. "Falling" throttle position voltage mode can be identified by the red flashing center LED. Pressing the #2 BUTTON will alternate between "rising" (**flashing green LED**) and "falling" (**flashing red LED**) throttle position sensor voltage.
7. **For "rising" throttle position voltage:** Press the #1 BUTTON while the GREEN LED is flashing. The GREEN LED will stop flashing and remain illuminated. The first digit of the lower display will now be flashing indicating that the desired throttle position sensor voltage can now be set. Pressing the #2 BUTTON will change the whole voltage reading from 0-4 volts. Once the whole voltage reading is obtained press the #1 BUTTON to select the desired tenths voltage. **See Figure 6**
8. **For "falling" throttle position voltage:** Press the #1 BUTTON while the RED LED is flashing. The RED LED will stop flashing and remain illuminated. The first digit of the lower display will now be flashing indicating that the desired throttle position sensor voltage can now be set. Pressing the #2 BUTTON will change the whole voltage reading from 0-4 volts. Once the whole voltage reading is obtained press the #1 BUTTON to select the desired tenths voltage. Press the #1 BUTTON to store TP voltage selection.



Figure 6

NOTE: The selected voltage should always be within .2 volts of WOT. i.e. – If rising TP voltage at WOT is 4.5vdc, the NOS WOT/Window Switch should be set between 4.3 – 4.5vdc. If falling TP voltage at WOT is 1.0vdc, the NOS/Window Switch should be set to 1.2-1.1vdc. This will prevent part throttle activation which can cause irreversible damage to the engine!

9. Once the TP voltage has been selected and stored, the 3rd & 4th digits should be illuminated with the 3rd digit flashing. This indicates that the ignition signal input is ready to be configured. Press the #2 BUTTON until the correct first digit, which corresponds with your specific ignition system in the chart below, appears. Once the correct number appears, press the #1 BUTTON. The 4th digit will now be flashing indicating you are ready to select the last number of the ignition input configuration. Press the #2 BUTTON until the second number needed to correspond with your ignition system appears. Press the #1 BUTTON to complete and exit the configuration mode. The NOS WOT/Window Switch can be configured to operate on any 4-cycle engine "tach output" signal from 1-18 cylinders.

Use the appropriate numbers to correspond with the vehicle ignition system;

00 – Use for non-waste spark DIS ignition systems i.e. - coil per plug

02 – Use for waste spark DIS ignition systems

04 – 4 cylinder engines connected to the "tach output" wire

06 – 6 cylinder engines connected to the "tach output" wire

08 – 8 cylinder engines connected to the "tach output" wire

10 – 10 cylinder engines connected to the "tach output" wire

12 – 12 cylinder engines connected to the "tach output" wire

NOTE: For applications that will rev above 10,000 RPM, add 20 to the configuration of the ignition signal input. The RPM on the display will read 10% of the actual engine RPM in this mode. For example – High revving 4 cylinder applications will use "24" instead of "04". If actual engine is 1000 rpm's, the display will read 100 rpm's. The maximum RPM for the NOS WOT/Window Switch is 20,000 RPM.

2.6 Verifying Settings and Operation of the NOS WOT / Window Switch

IMPORTANT! Disconnect the solenoid control wires! Make sure the nitrous bottle valve is closed!

CAUTION! EXERCISE EXTREME CAUTION WHILE SETTING THE WOT/WINDOW SWITCH, AS WORKING AROUND A RUNNING ENGINE IS EXTREMELY DANGEROUS! SECURE ALL LOOSE CLOTHING AND ITEMS TO SAFEGUARD AGAINST CONTACT WITH THE ENGINE! ACTIVE NITROUS AND FUEL SYSTEMS ARE EXTREMELY DANGEROUS!

1. Start engine and verify the RPM displayed on the NOS WOT / Window Switch matches actual engine RPM. If RPM differs, go back and configure the correct ignition signal input.
2. Verify that the TPS input is functioning correctly. The left two digits on the lower display will show actual “real time” TPS voltage. This value should increase as the throttle is opened and decrease as it closes on rising voltage equipped vehicles. If “0.0” is displayed, the TPS input is not connected properly. Press button #1 to see the maximum TPS voltage achieved. This is helpful in accurately setting WOT voltage. The maximum voltage reading can be cleared by pressing the #2 BUTTON.
3. To verify operation of the NOS WOT / Window Switch, lower RPM of the #1, #2 window switch and the TPS setting to a reasonable engine operating range. Set the shift light RPM to the same RPM as the #1 window switch.
4. Start the engine and bring engine speed up to “On RPM” setting and verify proper operation based on the chart in figure 7. Continue bringing the engine speed up to the “Off RPM” setting and verify proper operation based on the chart in figure 7.

	First Stage	Second Stage	Shift Light
Indicator Position	<i>Top LED</i>	<i>Lower Screen 3rd Digit</i>	<i>Lower Screen 4th Digit</i>
On RPM	Blue	2	S
Off RPM	Red	Overscore	N/A
Below On RPM	Off	Underscore	N/A
Below RPM Shift Point	N/A	N/A	Underscore

Figure 7

5. The center LED will illuminate red until the “TPS voltage” reaches the set voltage. Once the set voltage has been reached the center LED will illuminate green.
6. Once the “On RPM” of switch #1 and “TPS voltage” are met the bottom LED will illuminate blue. This indicates that the 12 volt and ground outputs are active.
7. Once you have verified proper operation of the NOS WOT / Window Switch, reset all of the values to the desired settings.

NOTE: If you do not want to have an RPM window switch function, select 0 RPM for the lower limit and 9999 RPM for the higher limit. The tan input wire needs to be connected to ground. NOS recommends the use of the high and low side of the window switch.

NOTE: Setting the window switch at the maximum rpm, or “rev-limit” of the engine can potentially cause severe engine damage, as some rev limiters will cut fuel only.



NOS Technical Support
Toll-Free Phone: 1-866-GOHOLLEY
Phone: 1-270-781-9741
Fax: 1-270-781-9772
www.nosnitrous.com

© 2011 Nitrous Oxide Systems, Inc. All rights reserved.

199R10482
Revision Date: 2-7-13