

MPS Deluxe Air Clutch Installation Instructions

The MPS Deluxe Air Clutch was designed to allow the rider to control the release speed of the clutch lever after releasing a button. It also features an adjustable clutch position switch. The Deluxe Air Clutch is a perfect interface for a delay box as well.

Mounting – Remove your old clutch lever assembly and replace with the MPS Deluxe Air Clutch Assembly. To install the clutch cable you will need to remove the ¼” -28 air cylinder rod end bolt and the 10mm x 1.25 bolt that secures the cylinder mount arm to the clutch perch. Install the cable as you would any clutch cable and re-install all parts removed. Slide the Pro Pushbutton over the bars and secure with the set screw.



Plumbing – Locate the supply line from your air shifter tank. Cut the line square in a convenient spot with a razor blade or plastic tubing cutter. Install the tee fitting in the line. Push the line as far into the fitting as it will go. Pull out to lock the line in place. To remove the line from the fitting, push down on the retaining ring on the fitting and the line. While holding down the retaining ring pull the line out of the fitting. Next insert the provided ¼” poly line into the third outlet of the tee fitting. Route the line to the Deluxe Air Clutch air valve and insert into the inlet fitting. You can easily check for leaks by airing up the tank and spraying windex on all fittings and connections.

Launch Button & Air Valve Wiring

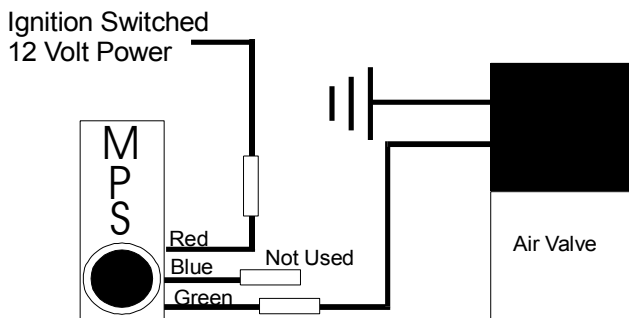

Electrical – The Deluxe Air Clutch is fitted with an Adjustable Clutch Position Switch for activating launch rev limiters, nitrous, timers, etc. The clutch position switch is a single pole double throw type. The wire colors for the clutch position switch are as follows: red – common, blue – normally closed, and green – normally open. When the clutch lever is out the red and blue are connected. When the clutch lever is pulled in the red and green are connected. You will need to follow your particular launch rpm control manufacturers instructions for

wiring the clutch position switch. Generally, most two stage rev limiters will use only the red and the green wire leads. The **Pro Pushbutton** is a momentary single pole double throw switch with the following wire colors: red – common, blue – normally closed, and green – normally open. The red common wire will go to a ignition switched 12 Volt power source. The green normally open wire will go to one of the black wires on the electric air valve. For delay box applications instead of one of the black wires on the electric air valve connect to the switch terminal on your delay box. The **Electric Air Valve** has two black wires. These can be interchanged. One should be wired to the green normally open wire from the Pro Pushbutton. For delay box applications instead of the green on the Pro Pushbutton connect to the transbrake terminal on your delay box. The other should be attached to a good ground.

Testing the Deluxe Air Clutch – Air up the air tank. With the engine off, and the ignition switch on, pull in the clutch lever until it stops. This will be a little short of the handlebar to leave room for your fingers. Push in and hold the Pro Pushbutton. This will charge the air cylinder and hold the clutch lever in. Now while holding the launch button in put your fingers around the handlebar. Now release the Pro Pushbutton. The clutch lever should release. Try it again in neutral with the engine idling. This will check for any possible RF interference. You will need to check your launch rpm control for proper operation as well. To adjust the release speed of the lever turn the

thimble of the **Clutch Release Needle Valve** counterclockwise for faster release speed and clockwise for slower release speeds. Note: Slower release speeds will cause slower reaction times. Play with this setting while you watch the lever to get a starting baseline. To adjust the **Clutch**



Position Switch; first start the bike, pull in the clutch, put it in 1st gear, and slowly release

the lever by hand until the bike starts to move on its own. Now scribe the lever to index this point in the lever travel.



Disconnect the red and green wires on the Clutch Position Switch. Using a multi-meter check for continuity between these wires. You should have continuity when the lever is pulled in and lose continuity as the lever is released. The exact point that the launch rev limiter is released is when you lose continuity. Moving the small adjustment triangle will change the launch rev limiter release point. It should be adjusted to the marked point on the lever for a starting point. Safety Tip: Do not ever open the throttle unless you are staged and ready to go!

If you have any more questions we have a Frequently Asked Questions page at our web site as well as the telephone tech support. Thank you for your purchase of this MPS product. All products sold by MPS are for use at closed course competition events and not for use on public streets or highways.

Launch Button & Air Valve Wiring With Delay Box

