



## 6.86" Pro Dash Quick Start Guide

553-112



# CONTENTS:

Package Contents .....	3
Mounting .....	3
Connections .....	5
Main Connector .....	5
CAN Extension Harness .....	6
USB.....	7
GPS Antenna .....	7
Cleaning .....	7
Touchscreen Basics .....	7
Main Menu.....	8
Modifying Channels on a Preconfigured Layout.....	10
Saving Gauge Screens .....	10
Quick Save .....	10
Rename and Save.....	11
Building a Custom Gauge Screen .....	11
Add Gauges .....	11
Customizing the Gauge .....	11
Backup/Restore .....	13
Data Log Playback .....	14
Firmware Upgrade.....	14

## **ATTENTION!**

THE USB FLASH DRIVE INCLUDED WITH YOUR PRO DASH CONTAINS A DETAILED USER MANUAL. ONE MAY ALSO BE FOUND ONLINE AT [www.holley.com](http://www.holley.com).

## Introduction

The Holley EFI 6.86" Pro Dash is customizable with a variety of gauge and indicator screens that can be programmed to display any parameter you need from a Holley EFI system. It also includes an integrated ten LED shift light as well as two LED's on the top left and two on the top right that can be programmed as desired. This quick start guide will get you up and running with your new dash. A detailed User Manual can be found on the USB flash drive included with your product.

## Package Contents



## Mounting

The product has four 10-32 tapped mounting holes for securing the unit. There are two basic ways to mount the dash, "surface" and "flush" mount. Included with the contents of this kit is a separate template with a 1:1 layout for both methods. The "Flush Mount" allows the user to recess the product to facilitate a "flush" mounting option, which recesses the unit, please be aware that brackets to support the back of the dash will need to be fabricated. The "Surface Mount" simply mounts the unit to a flat face.

Included are four 5/16" long 10-32 screws if the dash is mounted solidly to a "thin" (1/16") mounting surface. Also included are four 1/2" 10-32 long screws and four vibration dampening grommets that can be sandwiched between the dash and mounting surface in high vibration applications such as off-road, etc. Make sure that you DON'T use too long of a mounting screw, as it may crack the case if it bottoms out.

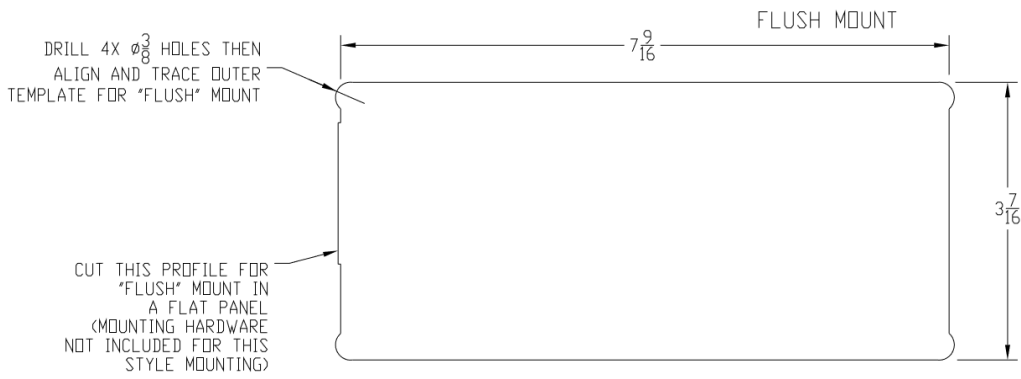
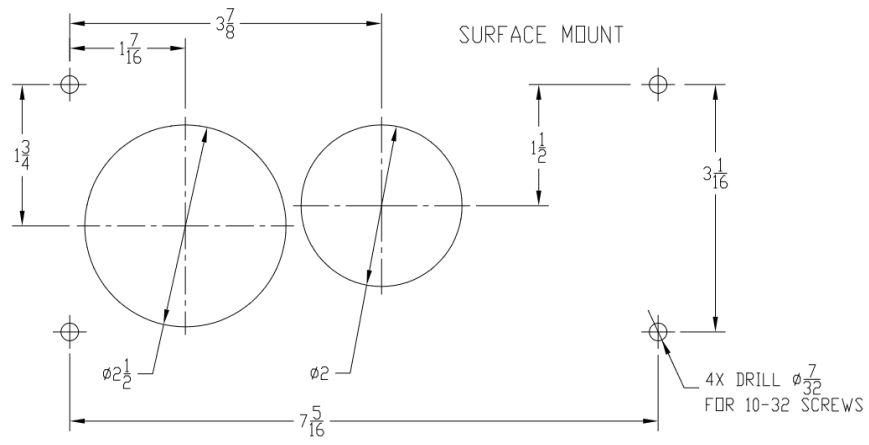

## Connections

### Main Connector

A 34 pin CAN/power harness supplied with the Pro Dash and is used to for power, communications and I/O.

The following are the required connections:

Loose Black – Connect to a “clean” ground source. Don’t ground to poor sources such as sheet metal, or a ground point that does not have solid connectivity back to the battery.

Loose White – Connect to a “clean” switched battery power source

Loose Red – Connect to a “clean” continuous battery power source

“Clean” = a connection that does not share the same connections as “dirty” sources such as coils, a starter, solenoids, fans, etc., that have a lot of electrical noise or solenoid fly-back voltage.

CAN – Connect the harness from the CAN connector on the vehicles EFI main harness to the dash using the supplied male/female 4’ CAN/Power extension. Place the supplied terminator into the empty CAN connector. The terminator must be used at the end of the CAN cable.

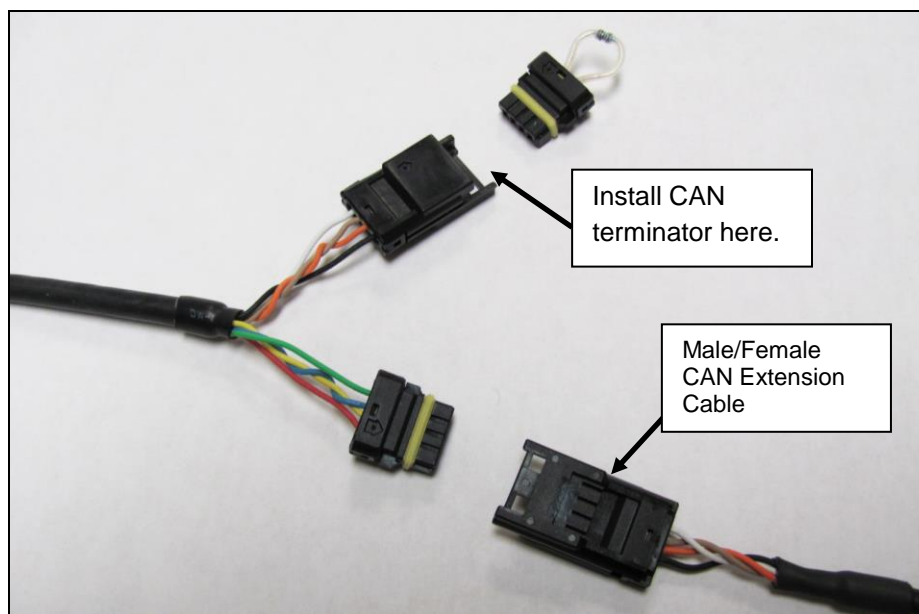

Holley EFI main harnesses use two types of CAN connectors. Earlier harnesses use a 2 pin metripak connector. The kit includes an adapter to go from this to the 4’ extension harness (note the white power and black ground wires are NOT needed for the Pro Dash, but need to be connected if other CAN devices require it for their power supply). Later harnesses plug directly into the 4’ extension harness.



Old Style CAN Adapter

The CAN harness attached to the dash includes both male and female CAN connectors. These connectors are wired in parallel to allow daisy chaining of multiple devices on the CAN bus.

Note that the Pro Dash does not use the CAN cabling to supply power and ground for it, unlike some other Holley EFI CAN devices, nor does the Pro Dash supply power to the CAN cabling, which is provided by the EFI harness.

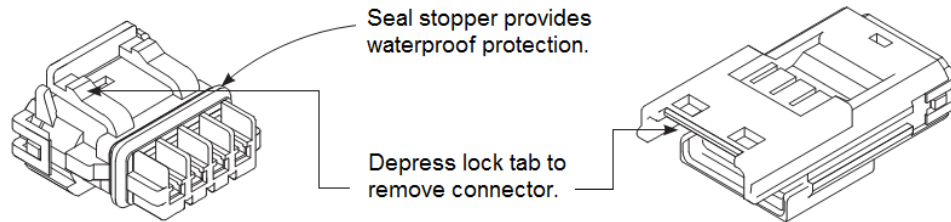

### Pro Dash CAN Cable Description

Pin	Function	Description
1	+12V	Power (pass through between connectors, not used for Pro Dash)
2	CAN1H	CAN_H Holley EFI communications
3	CAN1L	CAN_L Holley EFI communications
4	GND	Ground (pass through between connectors, not used for Pro Dash)

### CAN Extension Harness

The dash is supplied with a 4' CAN extension harness. Holley also offers the following replacement harnesses:

**558-451** – 1 foot

**558-452** – 4 feet

**558-453** – 8 feet

**558-454** – 12 feet

Additional wires can be installed to use additional functions in the Pro Dash. Consult the connector diagram and main user manual for more information.

1	2	3	4	5	6	7	8	9
GND	12V	SSR1	SSR2	SSR3	SSR4	CAN1H	CAN1L	CAN2L
10	11	12	13	14	15	16	17	
CVBS1	CVBS2	SW4	SW3	SW2	SW1	CAN2H	5V_EXC	
18	19	20	21	22	23	24	25	
AIN_1	AIN_3	AIN_5	AIN_7	AIN_9	AIN_11	AIN_13	IGN	
26	27	28	29	30	31	32	33	34
GND	AIN_2	AIN_4	AIN_6	AIN_8	AIN_10	AIN_12	SPD1	SPD2

#### Notes:

1. The 12V main power input (pin 2) also provides backup for the internal clock and GPS.
2. IGN (pin 25) needs to be connected to 12V to turn on the unit (low current input).
3. SSR1-SSR4 are low-side solid state relays, 1.5 Amp max.
4. 5V\_EXC is used to power sensors, 450mA max.
5. CVBS inputs are reserved for future use.

The unit will draw approximately 5 mA in standby to maintain its real time clock and GPS information for quicker acquisition.

## USB

The unit has two standard USB type C locking receptacles (USB 2.0). Connect the supplied locking cable to either of the USB ports on the back of the unit and tighten the thumbscrews.

This cable provides a type 'A' receptacle that can accept USB flash drives for saving data logs, uploading gauge screen layouts, background images, or firmware updates. You may also use these to connect to a USB mouse or keyboard if you do not want to use the integrated touchscreen for configuration.

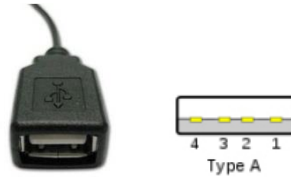

The USB flash drive that is included with your unit contains a user manual and can be used to transfer configurations and log files to your computer.

## GPS Antenna

Install the GPS antenna where it has clear view of the sky to the horizon for best reception. The label needs to face down, with the black plastic part of the antenna facing up. The antenna comes with a built-in magnet and can also be permanently mounted. For racing applications, it is recommended that the antenna be permanently mounted using the included double-sided VHB tape.

Connect the SMA connector to the GPS antenna connector on the back of the unit. Do not overtighten the connector, 3-5 in lbs max.

## Cleaning

If screen needs cleaning, use the supplied microfiber cleaning cloth. Do not use harsh chemical cleaners on the touch screen display.

## Touchscreen Basics

The Pro Dash has a capacitive touch screen display similar to many cell phones and does not require a stylus. While thick gloves may not work properly, some racing gloves are available with integrated finger pads that work with touch screens. The touch screen is used for configuration and EFI tuning. A stylus can be purchased (if desired). Make sure that it is for a capacitive touch screen, which would be used for a cell phone.



## Main Menu

Pressing anywhere on a gauge screen will bring up the navigational buttons. To access the main menu choose 'Menu' in the upper right corner of the screen.

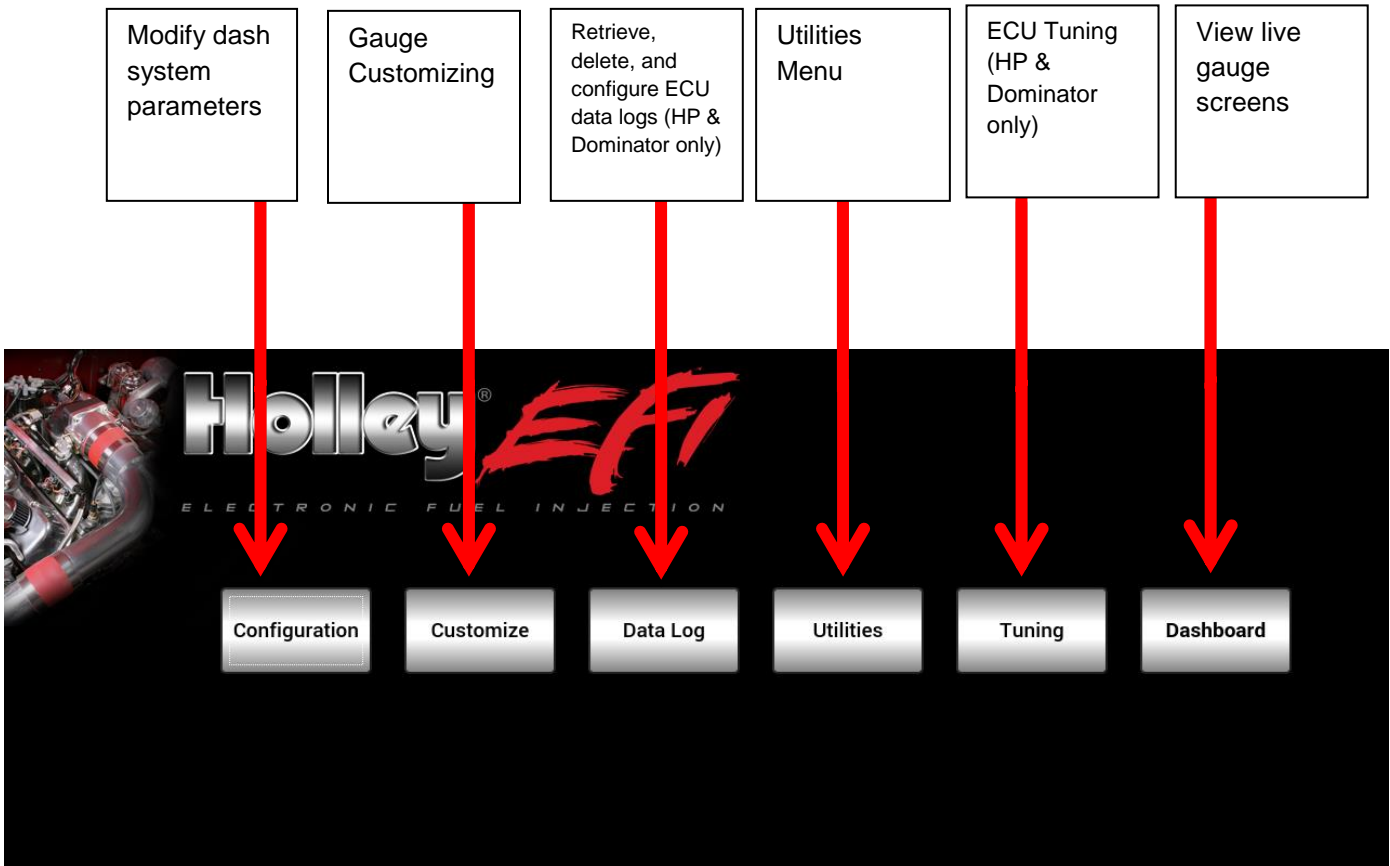

## Preconfigured Gauge Screens

The following will appear the first time the dash is powered with an ECU connected, or when changing to a different type of ECU:

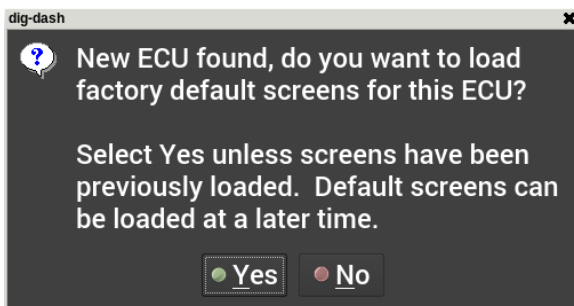

Selecting yes will load the appropriate default screens for your ECU.



## Preconfigured Gauge Screens

(HP and Dominator default screens shown, Sniper and Terminator X defaults will vary slightly)



Layout 1

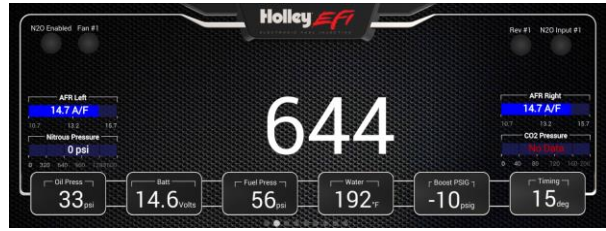

Layout 2



Layout 3



Layout 4



Layout 5



Layout 6



Layout 7



Layout 8

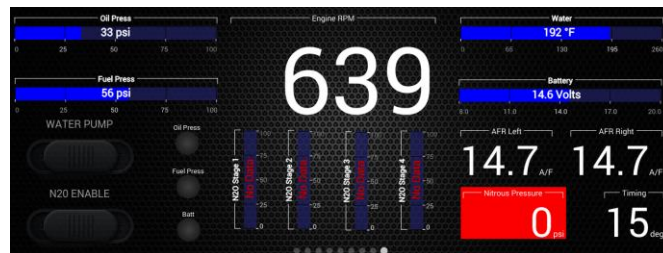

Layout 9

## Modifying Channels on a Preconfigured Layout

Choosing 'Customize' from the Main Menu enables the gauge customization mode. Entering this mode will allow any of the preconfigured layouts to be modified, or one may be built from scratch.

Any gauge channel can be changed to meet user needs. To do this, touch the gauge you wish to modify and push 'Customize'. At the top right corner of the customize gauge menu is a button that will allow the user to redefine the channel being displayed. For instance, "RPM" below could be changed to display Boost.

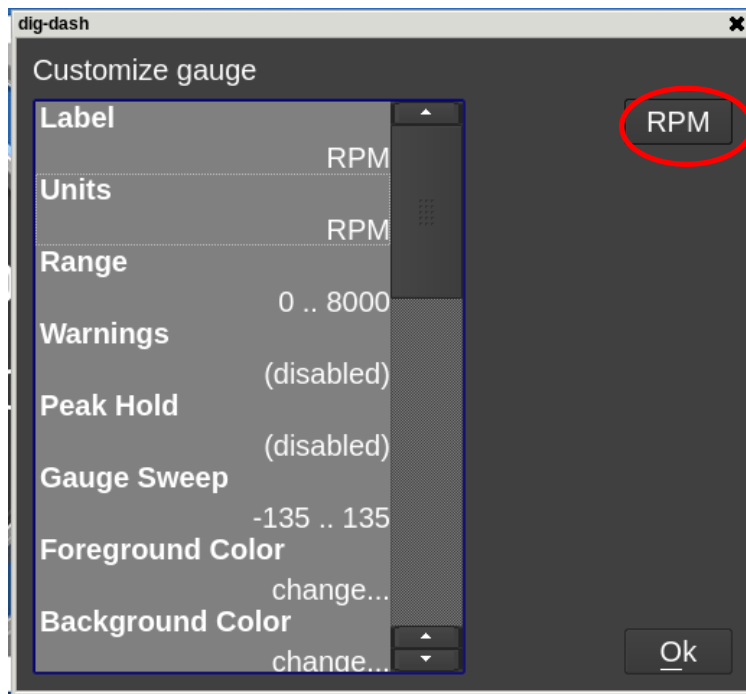

**NOTE: Only the gauge value being displayed will be updated, the user MUST manually change Labels, Units, Range, Warnings etc. with proper values as these will NOT be updated automatically! Refer to the 'Customizing Your Layout' Section of the user manual for instructions on gauge customization.**

## Saving Gauge Screens

### Quick Save

There are two ways to quickly save a gauge layout:

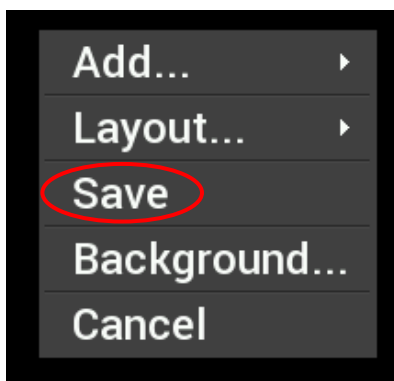

Option 1:

Touch any blank area of the screen and choose 'Save'



Option 2:

Choose the top right navigational button labeled 'Save'

## Rename and Save

The export function (below) will allow any gauge layout to be renamed and saved internally or to the included USB flash drive. To export a layout (single screen), touch any bare area of the background. Choose Layout >Export

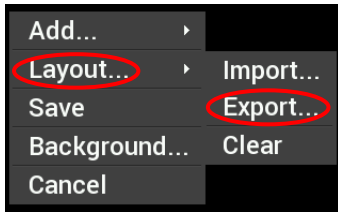

**NOTE: The last 'saved' gauge screen will be loaded by default at each power-up.**

If a specific default screen is desired, go to the Main Menu and select Configuration, then deselect Auto and select the desired initial layout number.

## Building a Custom Gauge Screen

To begin building a custom layout from a blank template, touch any bare area of the background. Choose Layout >Clear.

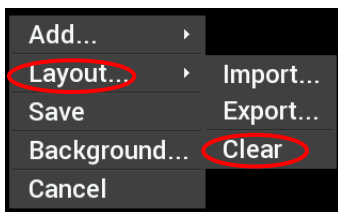

## Add Gauges

1. Select 'Add'
2. Select 'Gauge'
3. Select Value to Monitor
4. Select Gauge type

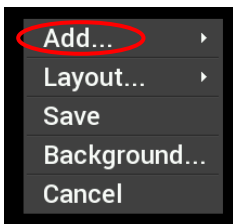

Step 1

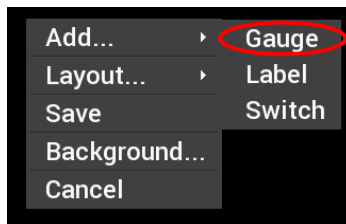

Step 2

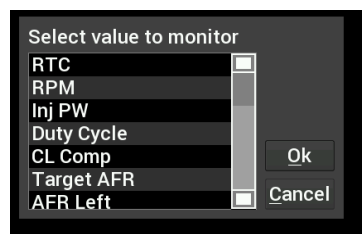

Step 3

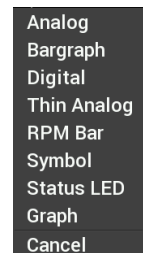

Step 4

## Customizing the Gauge

While in 'Customize' mode, touch the gauge you would like to modify and a menu will appear. To move the gauge, select 'Move' (A) and drag the gauge to place it in the desired location. To customize the visual properties and warning indicators, select 'Customize' (B) from the pop up menu. In the scroll window, you can see the parameters that are configurable.

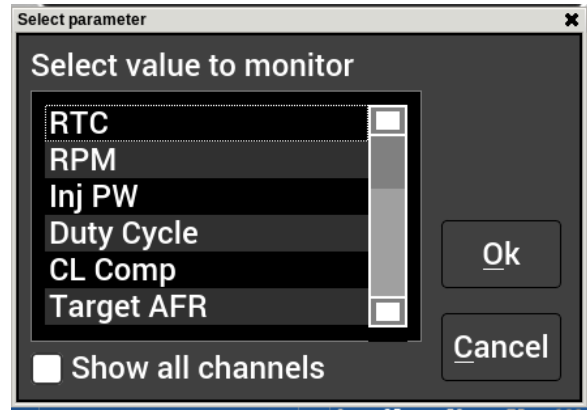
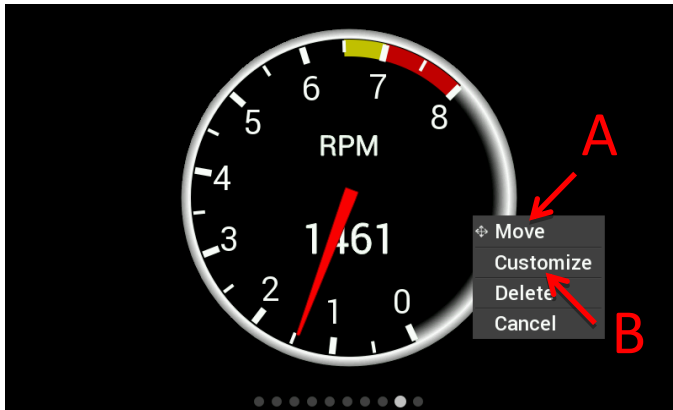

## Integrated LED Light Bar

The 6.86" Pro Dash contains 14 integrated LED lights that can be user programmed for many functions. The Center 10 LED's are used for a shift light. The outer four (LED's A, B, C, D) can be custom configured for many uses.

### 10 LED Shift Light Configuration

To access the LED Shiftlight Configuration below, start at the Main Menu and select Configuration>Dash Configuration>Shift Light>Configure Shift LED's

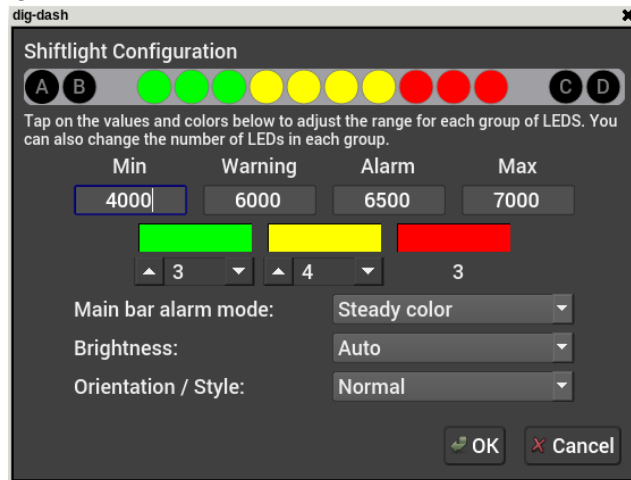

The 10 shift LEDs are split up into three groups, each of which can have the color programmed separately (click the color selection for each) as well as the number for each group (change the numeric value below the color). The engine RPM at which each segment starts and transitions to the next can be changed by editing the Min, Warning, Alarm, and Max values. Below the Min value, there won't be any LEDs active. In the example above, the first green LED will come on at 4000 RPM, and gradually all three green will be on by 6000. The first yellow Warning LED will come on at 6000, and all yellow will be on by 6500 (with each coming on in 125 RPM increments in this example). The first red Alarm LED will come on at 6500, with all present by 7000.

The "Main bar alarm mode" indicates what the LEDs will do when the Alarm value is met. The LEDs can remain solid or they can flash at a slow, medium, or fast rate.

The brightness can be set to "Auto" (will vary based on the ambient light sensor), or the user can set a fixed value from 1-6.

The “Orientation/Style” is the direction the lights will activate. The “Normal” selection will activate the lights from left to right. The “Inverted” selection will activate the lights from right to left. The “Outside In” selection will activate the lights from the outside(s) to the center.

### LED A, B, C, D Configuration

The two LEDs on each side, can be custom configured individually. Select each one to open the screen below. To create an indicator for any of the EFI channels, with limits set in this area, first check the “Override EFI status indicator” (everyone will likely want to check this and configure it this way). If this is not checked, the color and channel will come from the internal ECU or software driven values. You can then select both high and low alarm and warning settings, with specific colors for each. If you want an LED to not be active, just make the color black (as shown below for the “Normal” setting). The LED can set to be on steady, or blink with the bottom selection.

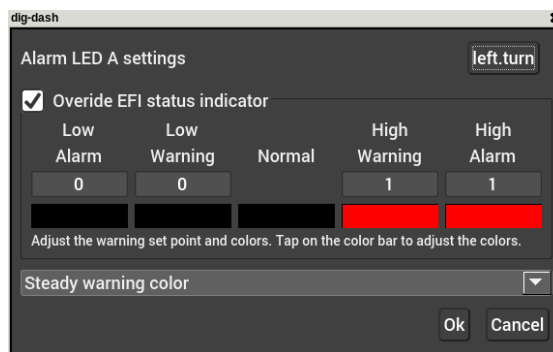

### Backup/Restore

A Backup and Restore option can be found under the Utilities menu.

Factory default configurations can be found at /internal/defaults/

### Backup

To create a backup copy of the complete dash configuration, choose Backup Configuration.

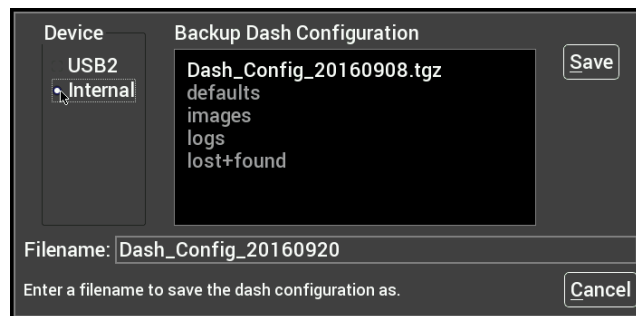

Navigate to where you want the backup file stored, adjust the filename if necessary, and press Save.

### Restore

To restore a previously saved configuration, select the Restore Configuration from the menu, locate the desired .tgz file and press Restore.



## Data Log Playback

The Holley EFI Pro Dash will play back logs that have been locally recorded using the 'Record' button or retrieved from an HP or Dominator ECU. Pressing the 'Playback' button on the right side of the dashboard screen allows you to play back these logs from the dash's internal storage or a USB flash drive.



## Firmware Upgrade

New or additional features developed by Holley can be added to the Pro Dash by updating firmware. These updated firmware files can be obtained by contacting tech service (270-781-9741 or 1-866-464-6553) or they may be downloaded from our website ([https://www.holley.com/support/resources/#Fuel\\_Injection](https://www.holley.com/support/resources/#Fuel_Injection)).

To perform a firmware update, follow these steps:

1. Extract the contents of the firmware .zip file onto the included USB flash drive (unzip files and put on USB flash drive). Always use the included USB flash drive as others may not work properly.
2. Connect the USB flash drive to the USB cable on the Pro Dash.
3. Select 'Update Firmware' from the Configuration menu and follow the on screen prompts. The firmware will automatically update.
4. Verify the version number using the About button after turning the dash off and on again.

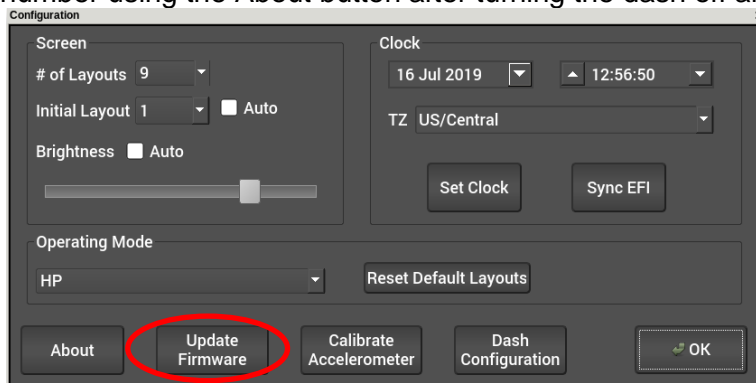

**Holley Technical Support**  
**1-866-464-6553**

**199R11730**  
**Date: 8-1-19**